

CONBOR

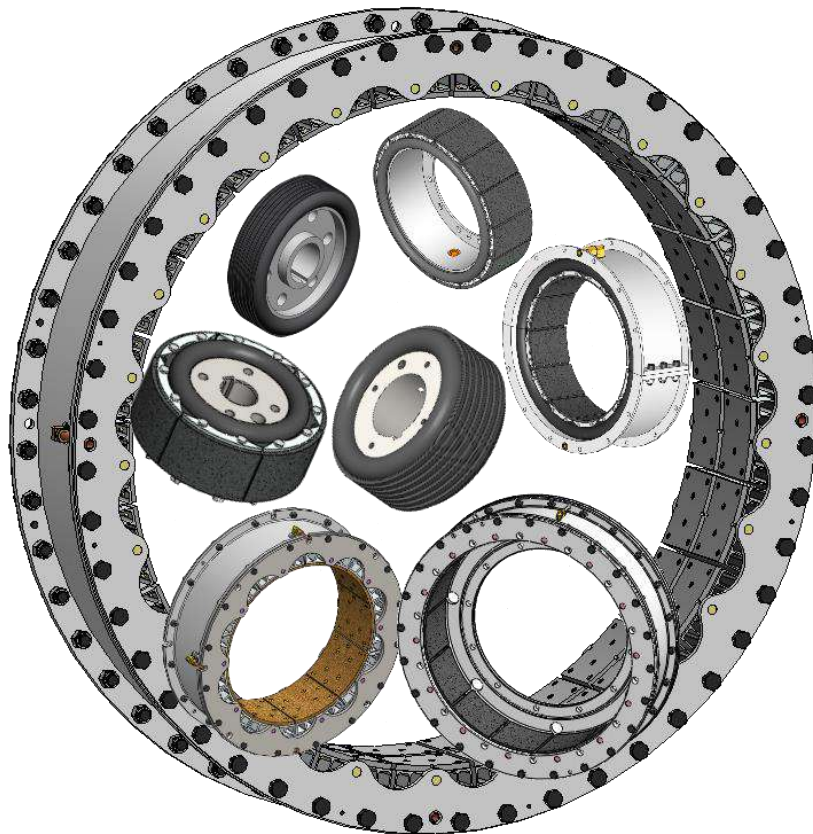

Brasileiros Movimentando a Indústria Brasileira

ELEMENTO PNEUMÁTICO EI
TAMANHOS DE 03 a 14
COM 01 FLANGE
SIMPLES EM TODOS OS TAMANHOS
BIPARTIDO A PARTIR DE 6 EI

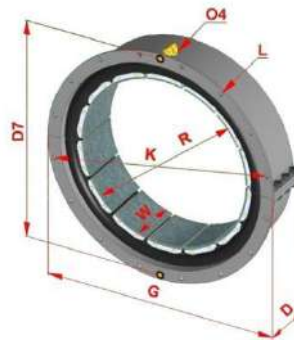

Modelos	Torque	K	D	R	D7	G	L		W		O4
							Nº	Dia.	Nº	Larg	
	N.m a 5,2 bar	Medidas em mm									NPT
3 EI	49	145,8	54,9	80	146,0	160,0	8	7,0	6	38,1	1/8" 27
4 EI	123	169,9	66,7	105	169,9	184,1	8	7,0	6	50,8	1/8" 27
5 EI	167	205,0	72,4	131	205,0	224,0	8	8,0	6	50,8	1/8" 27
6 EI	245	254,0	74,6	156	254,0	273,1	8	10,0	6	50,8	3/8" 18
8 EI	491	308,0	87,3	207	308,0	327,0	8	10,0	8	63,5	3/8" 18
10 EI	932	371,5	104,8	257	371,5	390,5	12	10,0	10	78,0	3/8" 18
12 EI	1.570	428,6	119,9	308	428,6	447,7	14	10,0	12	91,0	3/8" 18
14 EI	2.305	479,4	132,6	359	479,4	498,5	16	10,0	10	104,0	3/8" 18

ELEMENTO PNEUMÁTICO EI

TAMANHOS DE 03 a 45

COM 02 FLANGES

SIMPLES EM TODOS OS TAMANHOS

BIPARTIDO A PARTIR DE 6 EI

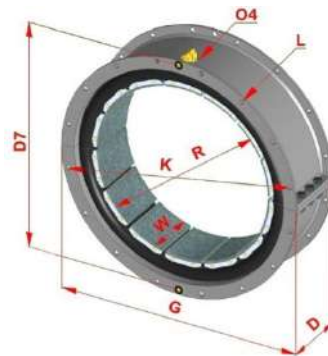

Modelos	Torque N.m a 5,2 bar	K	D	R	D7	G	L		W		O4 NPT
							Nº	Dia.	Nº	Larg	
Medidas em mm											
3 EI	49	145,8	57,4	80	146,0	160,0	8	7,0	6	38,1	1/8" 27
4 EI	123	169,9	69,8	105	169,9	184,1	8	7,0	6	50,8	1/8" 27
5 EI	167	205,0	75,6	131	205,0	224,0	8	8,0	6	50,8	1/8" 27
6 EI	245	254,0	78,0	156	254,0	273,1	8	10,0	6	50,8	3/8" 18
8 EI	491	308,0	91,0	207	308,0	327,0	8	10,0	8	63,5	3/8" 18
10 EI	932	371,5	108,8	257	371,5	390,5	12	10,0	10	78,0	3/8" 18
12 EI	1.570	428,6	124,0	308	428,6	447,7	14	10,0	12	91,0	3/8" 18
14 EI	2.305	479,4	136,5	359	479,4	498,5	16	10,0	10	104,0	3/8" 18
16 EI	4.120	571,5	168,0	411,2	565,2	596,9	8	13,0	10	130	3/8" 18
18 EI	5.199	619,1	168,0	462	619,1	647,7	12	13,0	11	130	3/8" 18
20 EI	6.278	669,9	168,0	513	669,9	698,5	12	13,0	12	130	3/8" 18
22 EI	7.456	720,7	168,0	563,6	720,7	749,3	12	13,0	13	130	3/8" 18
24 EI	8.829	771,5	168,0	614,5	771,5	800,0	16	13,0	14	130	3/8" 18
26 EI	10.791	831,9	176,2	665	825,5	863,6	16	16,5	16	134	1/2" 14
28 EI	12.459	882,7	176,2	716	876,3	914,4	16	16,5	17	134	1/2" 14
30 EI	14.225	933,5	176,2	767	927,1	965,2	16	16,5	18	134	1/2" 14
32 EI	16.187	984,3	176,2	817,5	977,9	1016,0	18	16,5	19	134	1/2" 14
36 EI	20.307	1095,4	176,2	919	1098,5	1133,5	18	20,0	22	134	3/4" 14
40 EI	25.917	1197,0	176,2	1021	1200,0	1235,0	20	20,0	24	134	3/4" 14
45 EI	30.705	1324,0	176,2	1148	1327,0	1362,0	24	20,0	27	134	3/4" 14

ELEMENTO PNEUMÁTICO EI

TAMANHOS DE 250 a 700

COM 02 FLANGES

SIMPLES E BIPARTIDO
EM TODOS OS TAMANHOS

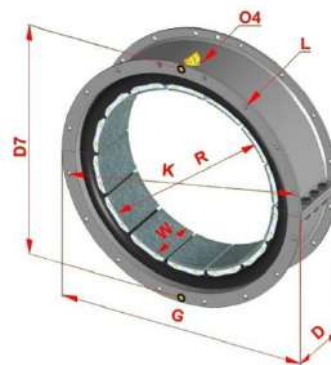

Modelos	Torque	K	D	R	D7	G	L		W		O4
							Nº	Dia.	Nº	Larg	
	N.m a 6,9 bar	Medidas em mm									NPT
250 EI	1.766	375,0	95,0	255	375,0	400,0	12	13,0	10	80	1/2" 14
300 EI	3.041	430,0	115,0	304	430,0	450,0	12	13,0	12	100	1/2" 14
400 EI	7.063	565,0	175,0	405	565,0	600,0	12	17,0	12	130	1/2" 14
500 EI	10.791	690,0	155,0	507	690,0	720,0	12	17,0	12	130	1/2" 14
600 EI	15.696	790,0	170,0	607	790,0	820,0	16	17,0	14	130	1/2" 14
700 EI	18.541	865,0	175,0	707	865,0	900,0	24	17,0	18	130	1/2" 14

**ELEMENTO PNEUMÁTICO IV-E
SÉRIE ESTREITA**

TAMANHOS DE 8 a 42

**SIMPLES E BIPARTIDO
EM TODOS OS TAMANHOS**

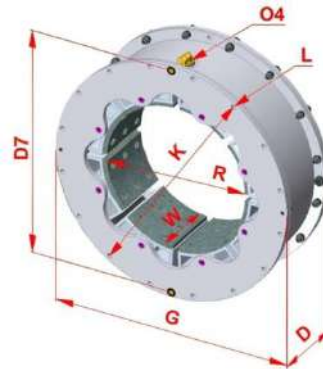

Modelos	Torque	K	D	R	D7	G	L		W		O4
							Nº	Dia.	Nº	Larg	
	N.m a 5,2 bar	Medidas em mm									NPT
8 IV-E	1.177	371,5	125,0	206,7	185,7	390,5	12	10,0	8	102	3/8" 18
9 IV-E	1.766	371,5	149,5	232,1	185,7	390,5	12	10,0	8	125	3/8" 18
10 IV-E	2.011	428,6	140,0	258,0	214,3	447,7	14	10,0	8	115	3/8" 18
11 IV-E	3.679	479,4	155,6	295,3	239,7	498,5	16	10,0	8	127	3/8" 18
14 IV-E	4.611	571,5	155,6	361,2	282,6	596,9	8	13,0	8	127	3/8" 18
16 IV-E	7.652	619,1	187,3	412,0	309,6	647,7	12	13,0	8	152,4	3/8" 18
20 IV-E	10.987	720,7	187,3	513,6	360,4	749,3	12	13,0	10	152,4	3/8" 18
24 IV-E	15.892	831,9	195,3	615,2	412,8	863,6	16	16,5	12	165,1	1/2" 14
28 IV-E	21.484	933,5	195,3	716,8	463,6	965,2	16	16,5	14	165,1	1/2" 14
33 IV-E	30.117	1095,4	195,3	843,8	549,3	1133,5	18	20,0	16	165,1	3/4" 14
37 IV-E	37.769	1197,0	195,3	945,4	600,1	1235,1	20	20,0	18	165,1	3/4" 14
42 IV-E	44.439	1324,0	195,3	1072,4	663,6	1362,1	24	20,0	20	165,1	3/4" 14

**ELEMENTO PNEUMÁTICO IV-L
SÉRIE LARGA**

TAMANHOS DE 14 a 76

**SIMPLES E BIPARTIDO
EM TODOS OS TAMANHOS**

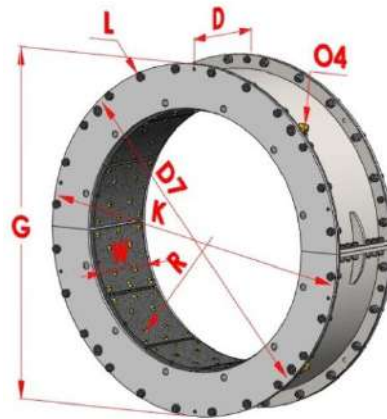

Modelos	Torque	K	D	R	D7	G	L		W		O4
							Nº	Dia.	Nº	Larg	
	N.m a 5,2 bar	Medidas em mm									
14 IV-L	10.200	571,5	294,0	361,0	565,1	596,9	8	13,0	8	254	3/8" 18
16 IV-L	13.700	619,1	294,0	412,0	619,2	647,7	12	13,0	8	254	3/8" 18
20 IV-L	19.400	720,7	294,0	514,0	720,8	749,3	12	13,0	8	254	3/8" 18
24 IV-L	26.300	832,0	294,0	615,0	825,5	863,6	16	16,5	10	254	1/2" 14
28 IV-L	35.600	933,5	294,0	717,0	927,1	965,2	16	16,5	10	254	1/2" 14
32 IV-L	50.000	1.082,7	295,0	818,0	1.070,1	1.114,4	24	16,5	12	254	1/2" 14
38 IV-L	81.900	1.216,0	349,0	971,0	1.219,2	1.254,1	20	20,0	12	305	3/4" 14
42 IV-L	98.600	1.324,0	349,0	1.072,0	1.327,1	1.362,1	24	20,0	14	305	3/4" 14
46 IV-L	114.000	1.485,9	349,0	1.175,0	1.460,5	1.530,3	24	23,0	16	305	3/4" 14
51 IV-L	191.000	1.663,7	464,0	1.302,0	1.651,0	1.701,8	32	23,0	18	406	1 " 11,5
52 IV-L	141.000	1.663,7	362,0	1.327,0	1.651,0	1.701,8	32	23,0	18	305	1 " 11,5
60 IV-L	259.000	1.905,0	470,0	1.535,0	1.885,9	1.955,8	36	26,0	20	406	1 " 11,5
66 IV-L	331.000	2.022,5	470,0	1.688,0	1.990,8	2.085,9	40	34,0	22	406	1 " 11,5
76 IV-L	426.000	2.276,5	470,0	1.948,0	2.244,8	2.339,9	48	34,0	25	406	1 " 11,5

ELEMENTO PNEUMÁTICO EIV
TAMANHOS DE 26 a 48

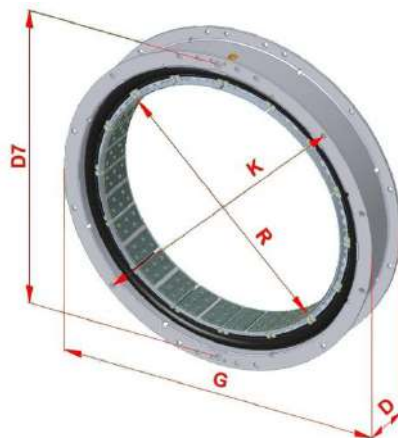

Modelos	Torque	K	D	R	D7	G	L		W		O4
							Nº	Dia.	Nº	Larg	
	N.m a 5,2 bar	Medidas em mm									NPT
26 EIV	14.340	849,3	176,0	665,0	835,0	882,7	12	18,0	24	121,0	3/8" 18
30 EIV	20.360	965,2	183,0	767,0	953,0	1.000,1	12	21,0	28	127,0	1/2" 14
35 EIV	28.590	1.127,1	196,0	894,0	1.111,0	1.165,2	12	21,0	32	127,0	3/4" 14
40 EIV	40.090	1.266,8	214,0	1.021,0	1.251,0	1.304,9	12	21,0	36	140,0	3/4" 14
48 EIV	66.570	1.473,2	230,0	1.224,0	1.454,0	1.511,3	16	21,0	42	165,0	3/4" 14

ELEMENTO PNEUMÁTICO EI-IV
TAMANHOS DE 4 a 10

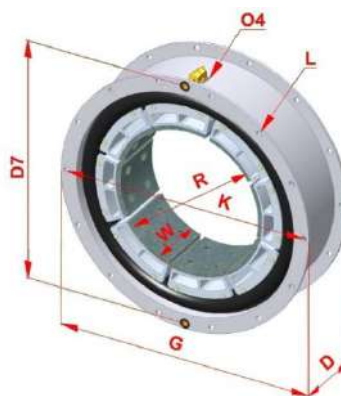

Modelos	Torque	K	D	R	D7	G	L		W		O4
							Nº	Dia.	Nº	Larg	
	N.m a 5,2 bar	Medidas em mm									NPT
06 EI-IV 4	128	254,0	78,0	105	254,0	273,1	8	10,0	6	51	3/8" 18
08 EI-IV 6	314	308,0	91,0	156	308,0	327,0	8	10,0	8	65	3/8" 18
10 EI-IV 8	618	371,5	108,8	207	371,5	390,5	12	10,0	10	76	3/8" 18
12 EI-IV 10	1128	428,6	124,0	257	428,6	447,7	14	10,0	8	90	3/8" 18

ELEMENTO PNEUMÁTICO EE

TAMANHOS DE 04 a 08

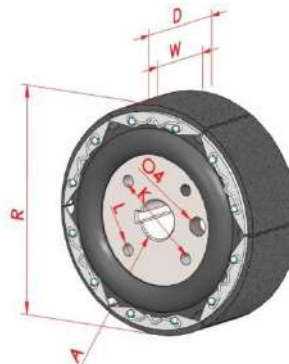

Modelos	Torque	K	D	A		M	R	L		W		O4
				Min	Max			Nº	Dia.	Nº	Dia.	NPT
	N.m a 5,2 bar	Medidas em mm										NPT
4 EE	50	54,0	44,5	22,2	38,1	19,0	100,0	4	5/16" 18	10	31,7	1/4" 18
6 EE	110	63,5	69,9	22,2	44,5	25,4	150,0	4	3/8" 18	6	50,8	1/4" 18
8 EE	270	111,1	82,6	31,8	88,9	31,7	199,2	4	3/8" 18	8	63,5	1/4" 18

ELEMENTO PNEUMÁTICO EE

TAMANHOS DE 09 a 24

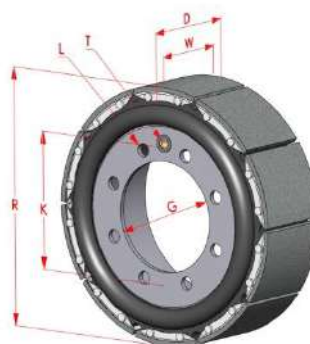

Modelos	Torque	K	D	R	T	G	L		W		O4
							Nº	Dia.	Nº	Larg	NPT
	N.m a 5,2 bar	Medidas em mm									
9 EE	450	117,5	105,0	224,6	117,6	88,9	8	13,0	9	82,6	3/8" 18
10 EE	520	133,4	98,5	250,0	141,2	107,9	8	13,0	10	76,2	3/8" 18
12 EE	900	184,2	111,0	300,8	192,0	158,7	12	13,0	12	88,9	3/8" 18
14 EE	1450	234,9	123,8	351,6	242,8	209,5	12	13,0	14	101,6	3/8" 18
16 EE	2260	244,4	154,0	401,6	244,4	209,5	8	13,0	12	120,7	3/8" 18
19 EE	3250	279,4	162,0	477,8	279,4	244,4	6	19,0	14	120,7	1/2" 14
21 EE	4330	342,9	162,0	541,4	343,0	307,9	8	19,0	16	120,7	1/2" 14
24 EE	5420	406,4	162,0	604	406,4	371,4	8	19,0	18	120,7	1/2" 14

ELEMENTO PNEUMÁTICO ES
TAMANHOS DE 06 a 08

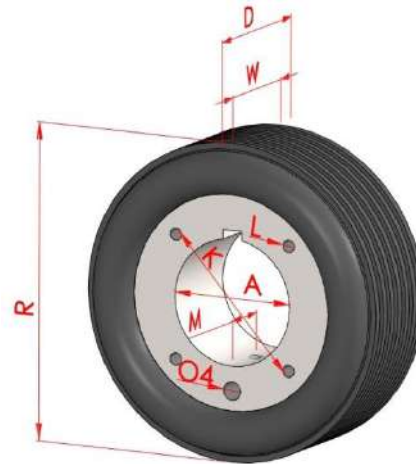

Modelos	Torque N.m a 5,2 bar	K	D	A		M	R	L		W	O4	
				Min	Max			Nº	Dia.			
				Medidas em mm								NPT
6 ES	190	63,5	77,8	22,2	44,5	25,4	150,0	4	3/8" 16	50,8	3/8" 16	
8 ES	430	111,1	90,5	31,8	88,9	31,7	200,8	4	3/8" 16	63,5	3/8" 16	

ELEMENTO PNEUMÁTICO ES
TAMANHOS DE 10 a 24

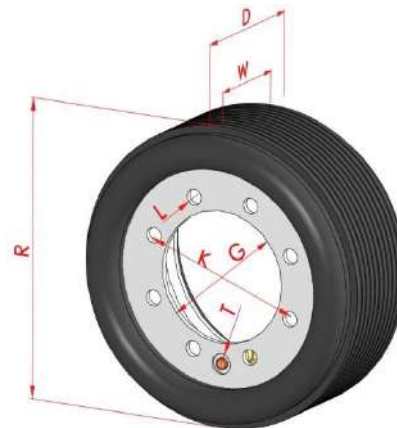

Modelos	Torque N.m a 5,2 bar	K	D	R	T	G	L		W	O4		
							Nº	Dia.				
				Medidas em mm								NPT
10 ES	800	133,3	105,0	248,5	141,2	107,9	8	13,0	76,2	3/8" 18		
12 ES	1480	184,2	115,0	300,8	192,0	158,7	12	13,0	88,9	3/8" 18		
14 ES	2720	234,9	133,4	353,2	242,8	209,5	12	13,0	101,6	3/8" 18		
16 ES	3920	244,4	168,3	401,6	244,4	209,5	8	13,0	120,7	3/8" 18		
19 ES	5610	279,4	168,3	477,8	279,4	244,4	6	19,0	120,7	3/8" 18		
21 ES	7580	342,9	168,3	541,4	342,9	307,9	8	19,0	120,7	3/8" 18		
24 ES	10050	406,4	168,3	604,8	406,4	371,4	8	19,0	120,7	3/8" 18		

ELEMENTO PNEUMÁTICO EV
TAMANHOS DE 12 a 40

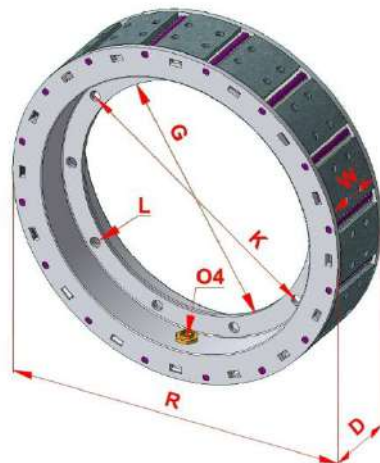

Modelos	Torque	K	D	R	G	L		W		O4
						Nº	Dia.	Nº	Larg	
	N.m a 5,2 bar	Medidas em mm								NPT
12 EV	1350	177,8	142	303,0	152,4	10	10	8	120	1/4" 18
14 EV	1890	222,3	142	353,0	193,7	12	10	10	120	1/4" 18
16 EV	2530	273,1	142	404,0	244,5	8	13	12	120	3/8" 18
19 EV	3700	349,3	142	480,0	308,0	10	13	12	120	3/8" 18
21 EV	4.830	400,1	142	544,0	362,0	8	19	14	120	3/8" 18
24 EV	6.200	463,6	142	607,0	425,5	10	19	16	120	3/8" 18
27 EV	7.990	539,8	142	684,0	501,7	12	19	18	120	3/8" 18
30 EV	12.500	584,2	180	760,0	533,4	14	19	14	152	1/2" 14
34 EV	16.150	685,8	180	861,0	635,0	16	19	16	152	1/2" 14
40 EV	26.400	812,8	208	1.014,0	762,0	18	19	18	178	1/2" 14